

College of Patent Agents & Trademark Agents

*Patent Agent Skills Examination
Part 1 Component B Sample Exam*

Purpose statement: The sample exam and sample answers are for informational and preparatory purposes only. They are intended to offer prospective test-takers a general understanding of the type and format of questions that may appear on the skills examination, as well as to demonstrate the level of detail expected in responses. For more information, refer to: <https://cpata-cabamc.ca/en/become-an-agent/information-patent-agent-qualifying-examinations/>

Representation: The sample exam does not represent the full range of topics, difficulty levels, or types of questions that may be encountered on the actual exam. The actual exam may contain questions that differ significantly in form and content. The subject matter is the same across both Components A and B of Part 1 for illustrative purposes. The subject matter for each component in Part 1 will be different on the actual examinations.

Predictive value: Performance on this sample exam should not be taken as an indicator of future performance on the corresponding skills examination. This sample is not intended to predict exam outcomes and should not be used as a test-taker's sole preparation material.

Answer key: The sample answers provided are for illustrative purposes only. They represent one of several possible approaches to answering these sample questions. Actual exam responses may vary, and there may be multiple valid ways to address a question.

Updates and changes: Exam content and policies are subject to change. While we aim to keep our preparation materials up-to-date, the sample exam and answers may not reflect the most current version of the actual examination.

No guarantee: Using these sample materials does not guarantee success in the actual skills examination. Examinees are encouraged to engage in comprehensive study and preparation to enhance their understanding of the subject matter.

Confidentiality: The actual examination content is confidential.

Feedback: Feedback on these sample materials is welcome. However, please be aware that individual responses or specific guidance on exam preparation cannot be provided.

Examination information

The *Patent Agent Skills Examination Part 1* takes place over two (2) days. Test-takers have three (3) hours on one day to complete Component A. Test-takers have three (3) hours on a subsequent day to complete Component B. Both components focus on strategy and drafting, each with its own background information and prior art. Each component is worth 75 marks; the two (2) components are scored together as a single examination worth 150 marks.

Component A consists of 5 questions worth a total of 75 marks.

Component B consists of 6 questions worth a total of 75 marks.

Components A and B will be scored together.

During the examination, test-takers have electronic access to the *Patent Act*, RSC 1985, c P-4 (“Patent Act”) and *Patent Rules*, SOR/2019-251 (“Patent Rules”), in addition to other background information or resources necessary to respond to the examination questions.

Instructions for test-takers

Review any background information provided. Answer the questions.

Avoid extraneous commentary not directly relevant to the question. Do not assume facts that are not provided.

When asked to support an answer, include relevant discussion or reasoning. While relevant source references (e.g., to case law, statutory provisions, or regulatory provisions) may be helpful to include, separate marks are not provided for such references unless specified in the question.

Point-form answers are acceptable, except where expressly indicated.

Component B (3 hours, 75 marks)

Background

A description of the technology, as the hypothetical inventor understands it, is provided in the form of a meeting transcript. The inventor has also provided the attached drawings. A search has been performed to assist you in evaluating the actual scope of the inventor's invention. The search has revealed the following pertinent references, namely: US Patents X,XXX,784 (D1), X,XXX,052 (D2), and X,XXX,953 (D3). You will assume the search is the most relevant of the prior art and you are cautioned not to impart your own knowledge into your analysis and preparation of the patent application.

Drawings

You have been provided with duplicate unmarked copies of the drawings for your use.

Client Interview (Transcript)

Your client arrives at your office one morning and you learn that she wants to pitch her latest invention to prospective investors (endearingly called "Lizards") on a popular television show.

You: So, I heard that you will be auditioning to pitch in the Lizards' Lair? Tell me more!

Client: Well, this past winter I came up with a great idea for an automobile accessory. After some experimentation, I built a prototype of an accessory for protecting a windshield from snow and ice. I have not yet shown it to anyone. I am encouraged by some market research that I did, which has remained confidential. Since I don't have the capability to manufacture the product, I figured I could use the Lizards' backing to negotiate a licensing deal with a third-party manufacturer. Do you think you can draft and file a suitable patent application for me?

You: When are you auditioning?

Client: Tomorrow at noon.

You: Well then, we'd better get to work! What exactly did you come up with?

Client: It is a new protection device that you would use when you park your car outside for an extended period of time in the winter. Basically, the device includes a continuous cover. The cover overlays the windshield as you see in Fig. A. My research shows that polyvinyl

chloride (PVC), commonly used in raincoats, is suitable for use with my protection device, but one could also make the cover out of any other flexible water-resistant material. Using a recycled plastic would make my invention more environmentally friendly and could be easily adapted from what is already known in the plastics field. The cover has a windshield-shaped periphery with side, top and bottom edges.

You: I'm not sure I understand the invention – is it a special style of bag that goes over a windshield?

Client: Not at all! As you know, winter weather can get pretty nasty so I needed to make sure the cover would not slide off the windshield due to snow accumulation or get blown away by the wind. One thing I did was to provide a support structure connected to the cover that supports the cover over the windshield in an extended state, so that it doesn't slide down under the weight of the snow. In my prototype of Figs. A and B, the support structure includes two adjacent but separate rectangular wire frames. Each wire frame includes a side support member that is close to each of the side edges of the cover and that extends from the top edge to the bottom edge of the cover, top and bottom support members extending from the side support member along the top and bottom edges of the cover, respectively, and a central support member interconnecting the top and bottom support members. But there are of course other ways to configure the support structure, and I'll get back to that later. The look of my device when it's on a vehicle is unique and will hopefully be eye catching.

You: Taking a few notes here...OK...please continue.

Client: In proximity to the two side edges of the cover there are attachment elements with loop members. They hold the cover to the car securely, so that the device won't get blown off by the wind, while still being very easy to use. So, the cover is maintained in position by this pair of loop members that are looped around the side mirrors, securing it to the car. As you can see from Figs. A and B, the loop members of my prototype are in the form of elastic closed loops that loop around the mirrors. The closed loops need to be elastic for easy installation and removal. Other options like Velcro ties could also be possible.

You: I also see that the side view mirrors are protected.

Client: Yes, in this version, the attachment elements also include mirror covers. Mirror protection is an additional benefit of my device, because it is not just the windshield but also the side view mirrors that can accumulate snow and ice. I designed a cover which is shaped similarly to a mitten, with the "hand" that covers the mirror and the "wrist" formed by an elastic closed loop that serves as the loop member. However, protecting the mirrors is

less of an issue, since it is usually quite easy to remove snow from a side view mirror, so the device could be provided without a mirror cover.

You: It sounds like a great idea. I can think of a number of retailers where this could be sold. But the form factor seems a bit large, and I expect some of the Lizards (potential investors) may suggest that it will cost more to transport than to make!

Client: Of course, the support structure must be collapsible or nobody will buy my device. Look at Fig. D.

You: It is barely recognizable! Please can you describe it.

Client: Well, the support structure is collapsible by collapsing the support members of the wire frames. When you come back to your car after shopping or in the morning, you remove the device from the windshield, shake off the snow from the water-resistant cover and then you fold the wire frames one over the other. This gives you a rectangular cover of double the thickness. Then you twist the folded frames, which causes them to give, and Voilà! The device becomes a compact item that you can put into a bag that will easily fit into the trunk and costs less to ship online. Isn't that brilliant? I used wires fashioned from steel that are rigid enough to give the needed support for the structure but lots of different materials could be possible.

You: Brilliant indeed.

Client: I have another prototype that I am working on, which has a support structure different from wire frames. Look at Fig. C: it includes two side support members that are in the form of straight ribs, one in proximity to each side of the cover. These two ribs make up enough of a support structure to maintain the continuous cover over the windshield in an extended state. I also included intermediate spaced-apart ribs, but I found that although they provide extra sturdiness, sufficient support is provided without these intermediate ribs, so I can make my device cheaper by omitting them. This simple support structure is of course also collapsible, by moving the support members towards each other when you're done, you grab the ribs at either end of the cover and collapse the device onto itself. Just imagine the convenience!

You: Can you also use the device in the summer?

Client: I guess my device could serve as a heat shield, although there are probably cheaper alternatives. The purpose of my device is for protection of the windshield against snow and other precipitation. In fact, I'm planning to offer a version with a heating wire embedded in

the cover for melting the ice. This would be somewhat more expensive but could be a great option for some users. Basically, whenever you start your car, such as with a remote starter, you begin the heating process. This type of heating wire is commonly used in lots of winter devices.

You: Very interesting. But let me ask you: wouldn't users be afraid that someone will steal their device? People usually stay in a mall for several hours at a time or park overnight in their driveways.

Client: According to my research, this would not be a barrier to entry on the market, at least not in Canada. But nonetheless, I am thinking of designing a model with a lock-strap connected to the support structure, as you can see in Fig. B. I may either carry two product lines or make all of the devices with the lock-strap; I still have not decided. The lock-strap has a buckle or another enlarged element at its free end. A heavy, flexible cut-resistant wire could be embedded in the lock-strap for extra protection. With the buckle inside the vehicle and the lock strap pinched between the door and door frame, the device is secure and cannot be easily removed.

You: It's a good thing that cars have two side view mirrors, otherwise you could have a problem, couldn't you?

Client: That's exactly right. If you only had a single loop member and attached it to one side of the car, then the other side of the device would be free to move around, which would be a disaster as soon as the wind would pick up. And by the way, the attachment elements I have drawn are really just an example.

You: How so?

Client: What I mean is that Fig. B shows mittens tethered to the side edge of the cover by a strap. But a manufacturer might prefer to connect the attachment element to the support structure, instead of or in addition to the cover. Also, even though the attachment elements have to be connected close to the side edges of the cover, this connection does not necessarily have to be half-way up the side edges of the cover as illustrated in Fig. B. For instance, the connection may be made slightly closer to the bottom edge of the cover as in Fig. C.

You: Actually, speaking of attachments, can you tell me a bit more about how the device is attached to the vehicle?

Client: Of course. The closed loop of the elastic wrist of Fig. B is not the only possible type of loop member. The loop member could also be two complementary elements that are not pre-formed in a closed loop but are attachable together to form that closed loop, for example two straps with Velcro™, belt attachments, snaps, buttons, etc. The loop members could also be configured to surround any other element of the car, for example something on the inside of the car like the steering column, gear shift or interior door handles. This way, upon installation, you would not only have sturdiness but anti-theft properties as well.

You: Thank you for the explanation. Do you have anything else to add?

Client: Yes, I have been considering putting wire framework into the mittens to give the mittens greater structure. The wire framework can give a triangular structure to the mittens with the apex pointing upwards and enabling snow to more easily slide off the mittens. I am somewhat fond of this arrangement because I would like to put my business' logo on the front and rear sides of the mittens so that it is on display to pedestrians passing by the vehicle. This isn't particularly useful if the snow piles on the loose fabric of the mittens and covers the logos, so vertical apex and steep sloping structure of the wire framing helps keep the logo visible. Also, I have a couple of designs we are working on for the shape of the wire framework that I think give my covers a unique look. We haven't quite finished these designs because we had an in-house designer who was fired and who deleted the copies of his work in our system the day he left. We still have some of the preliminary mock-ups but they need a little work before we can use them. I also came up with a special coating that I can apply to the PVC to make it hydrophobic. The hydrophobic coating improves the performance of the cover with melting snow and ice. I have found that a particular application process for the coating gives a superior texture and resilience to the coating. However, I want to keep this process in house for the time being.

You: I see. Anything else?

Client: Only that I have the results of a prior art search (giving you documents D1, D2 and D3). Have a look, there appear to be some similarities, but I am hopeful that you will be able to prepare a patent application that protects all versions of my device, and the method of how my device works. Please do your best so that I can strike a good deal with the Lizards. Broadly, the first shows a different collapsible windshield cover that is inserted within the vehicle. The second reference describes a windshield cover with plastic material that is attached by vacuum cups. The third reference describes a collapsible plastic sheeting that is secured between the doorframes and the door of the vehicle.

The front page and figures of D1 follow here:

(D1)

United States Patent

Patent Number: X,XXX,784

Shield et al.

Date of Patent: Jan. 1, 1989

AUTOMOBILE SUNSHIELD

The present invention relates to sunshields and specifically to automobile sunshields or shades. The sunshield of the present invention may be positioned against an interior window surface, such as the windshield, to act as a barrier and protect the interior of the motor vehicle against sun rays. This thereby reduces undesired weathering caused by sun rays and reduces the heat which tends to build up within the vehicle interior.

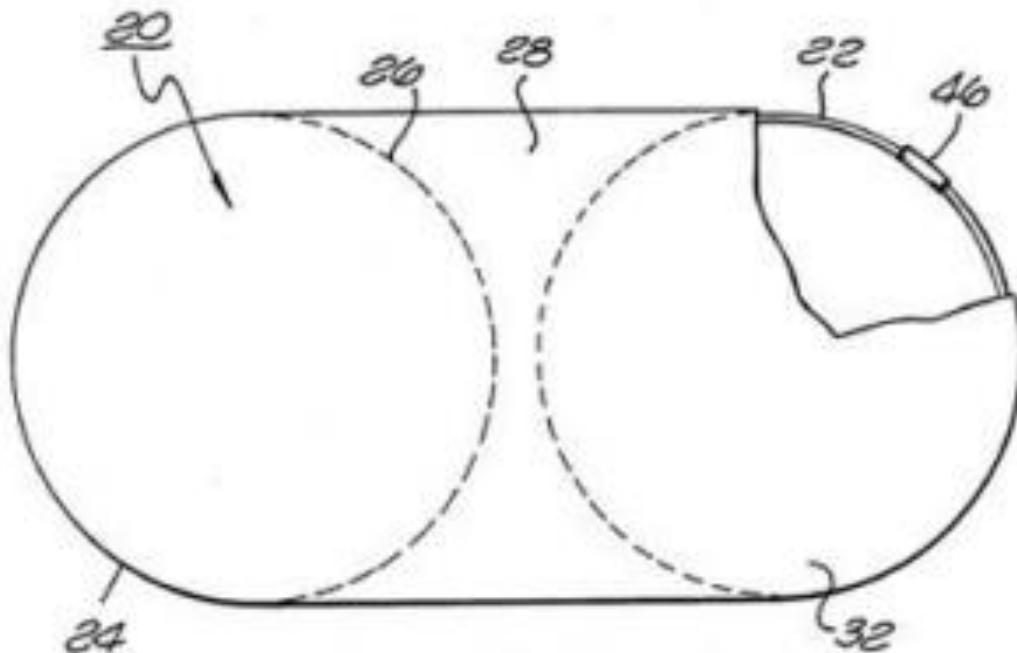

FIG. 1

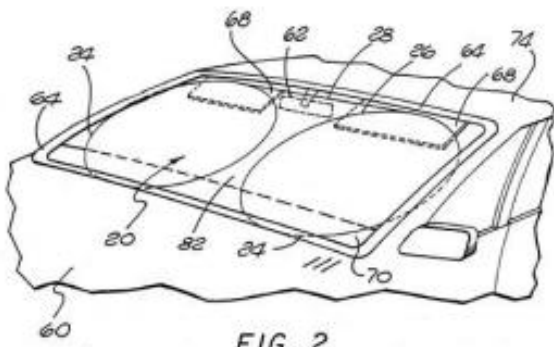

FIG. 2

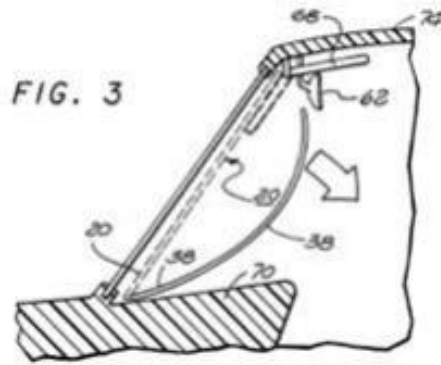

FIG. 3

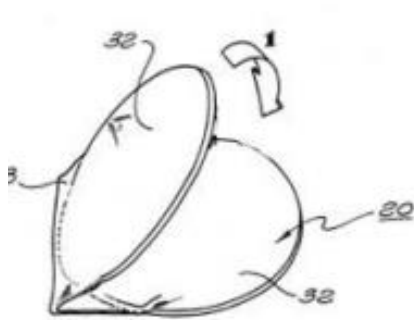

FIG. 4(A)

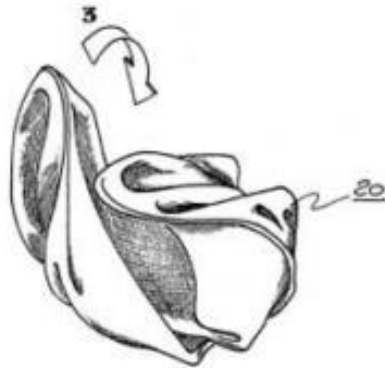

FIG. 4(B)



FIG. 4(C)

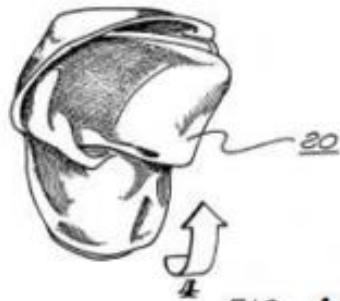

FIG. 4(D)



FIG. 4(E)

The front page and figures of D2 follow here:

United States Patent

Patent Number: X,XXX,052

(D2)

Cover et al.

Date of Patent: Jan. 1, 1949

WINDSHIELD COVER

This invention relates to automobile accessories and more particularly to a cover which is primarily intended for use on windshields of automobiles to protect them from being covered with snow, sleet, frost or fog.

Fig. 1 is a perspective front view of a windshield cover embodying our invention; the same being shown attached to the windshield of an automobile which is indicated in dotted lines.

Fig. 2 is a side view of side mirror covers according to another embodiment.

Fig. 3 is a rear view of the cover of Fig. 1.

Fig. 4 is a fragmentary sectional view illustrating the manner in which the suction cups are fastened to the windshield cover.

As shown in the drawing, our improved windshield cover is preferably constructed of a sheet of flexible material 5, such as plastic, or waterproof cloth, and may be provided with a peripheral binding strip 6 if desired.

Fig. 1.

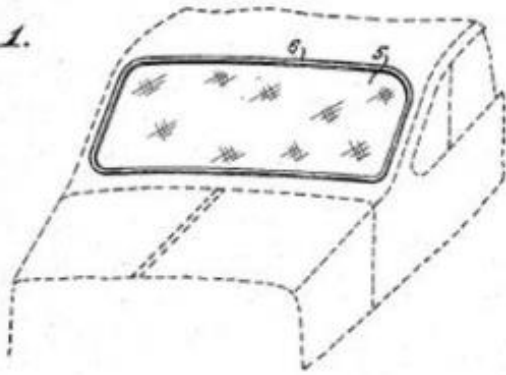

Fig. 2.

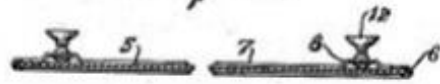

Fig. 3.

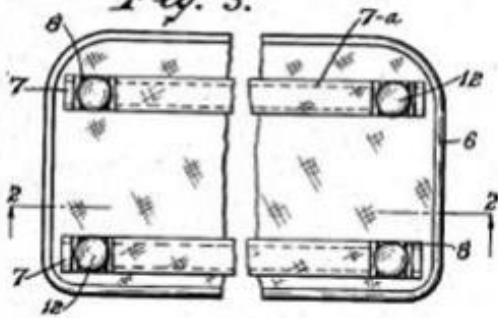
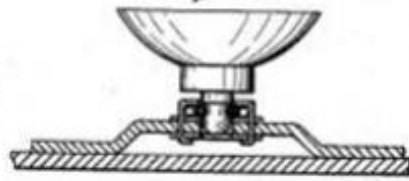

Fig. 4.



The front page and figures of D3 follow here:

United States Patent

Patent Number: X,XXX,953

(D3)

Protect et al.

Date of Patent: Jan. 1, 2010

COVER FOR WINDSHIELDS

This invention relates to devices for preventing the accumulation of snow, ice, and frost on the windshields, windshield wipers, air intake manifolds, and rear windows of vehicles. In addition, when used in the presence of sunlight, this invention relates to devices designed to protect a vehicle's interior surfaces and ambient air from heat build-up caused by the sun's rays.

FIG. 1 shows the device installed over the front windshield, windshield wipers, and air intake manifold of a vehicle, with the ends of the cover tucked between the doors and the doorframes of the vehicle.

FIG. 2 is a plan view of the cover.

FIG. 1 is a front view of the cover 1 made of opaque, reflective, snow-and-ice-repellent material such as, but not limited to, plastic or plastic-coated sheeting, which can be of any color desired. The cover 1 has a plurality of rigid supporting rods 2 attached to the underside of the cover, designed to span the space from the roof 3 of the vehicle to the hood 5 of the vehicle. The right and left ends of the cover 1 are designed to be enclosed within the vehicle, pinched between the vehicle doors 8 and the doorframes 9. These ends have a means, such as, but not limited to, short rods, also attached to the cover 1, designed to prevent the cover from being pulled out of the closed doors 8 of the vehicle.

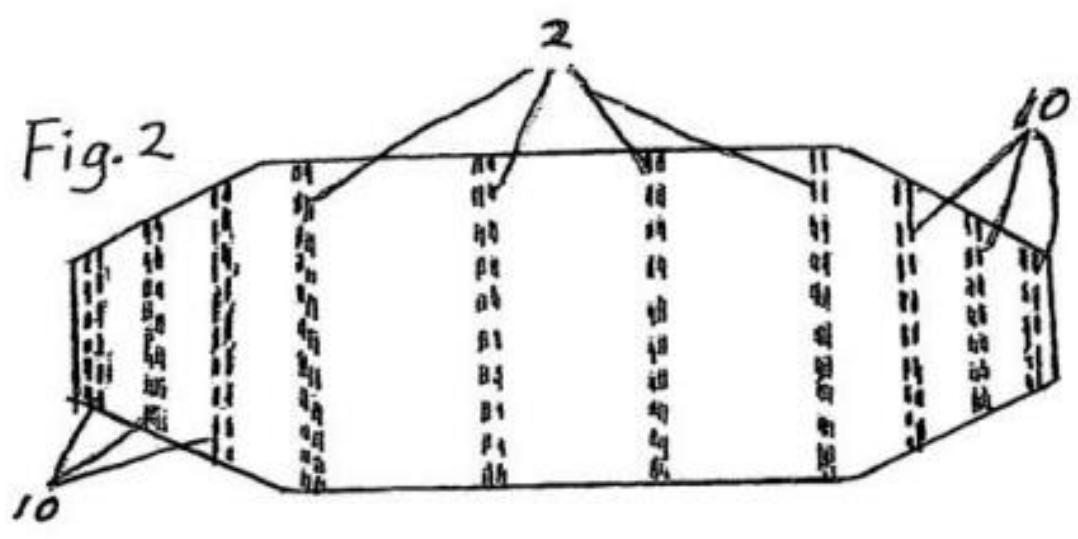
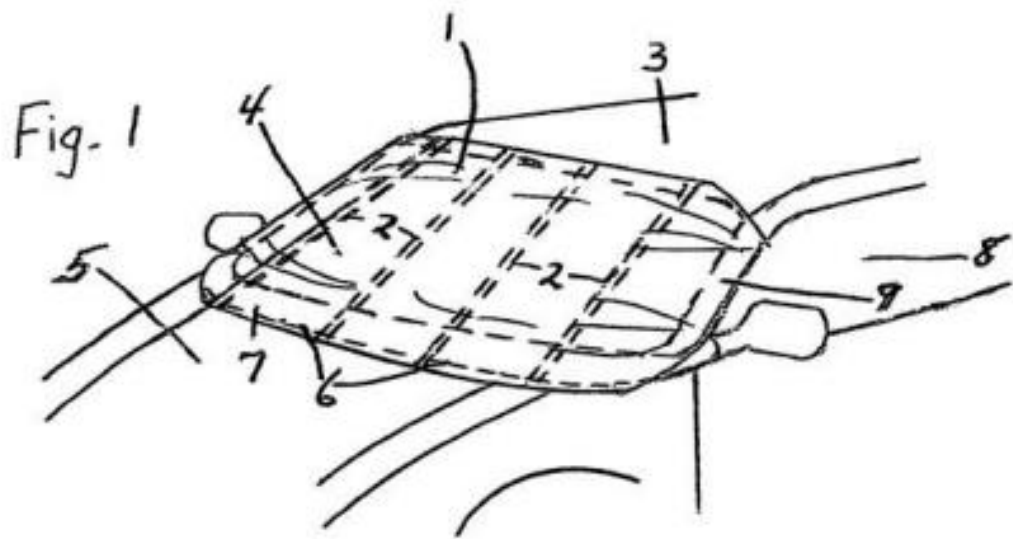

Question 1 [12 marks in total]

Identify reasoned claim drafting objectives for a potential patent application. Your answer should:

- (a) reflect at least one inventive concept for a single article of manufacture and the strategic, legal, or commercial advantage it provides **[5 marks]**;
- (b) distinguish between the inventive concept and the embodiments proposed by the inventor, highlighting which features are “additional” to the underlying inventive concept and are differentiated from the prior art **[2 marks]**; and
- (c) reflect on the scope of an additional independent claim of any type and the strategic, legal, or commercial advantage it provides. **[5 marks]**

Question 2 [30 marks in total]

Based on the claim drafting objectives identified in question 1:

- (a) Draft an independent claim for a single article of manufacture (i.e., an apparatus style claim) **[25 marks]**; and
- (b) Explain the scope and breadth of the claim as drafted in 3(a) and how it is differentiated from the prior art **[5 marks]**.

Claims require proper scope, characteristics, and structure. Claims must meet the requirements of the *Patent Act* (e.g., section 27) and the *Patent Rules* (e.g., section 60), reflect the identified claim drafting objectives, and have a logical organization.

Question 3 [4 marks in total]

| | |
|----------|--|
| Claim A. | The protection device of claim 1, the device comprising a strap with one end connected to support structure and the other end including an enlarged element. |
| Claim B. | The protection device of claim 1, wherein the cover comprises windshield wiper sheathes. |
| Claim C. | The protection device of claim 1, the attachment element comprising two complementary members attachable to form a closed loop. |
| Claim D. | The protection device of claim 1, the device comprising a strap with one end connected to support structure and the other end including an enlarged element. |

| | |
|----------|---|
| Claim E. | The protection device of claim 1, wherein the support structure comprises a rigid material. |
| Claim F. | The protection device of claim D, wherein the enlarged element comprises a wireless security device, wherein the wireless security device is configured to enter an alarmed state if the lock strap is compressed by a car door and to exit an alarmed state when disabled by a wireless signal. |
| Claim G. | The protection device of claim 1, comprising a heating wire. |
| Claim H. | The protection device of claim 1, wherein the cover is made of recycled plastics. |
| Claim J. | The protection device of claim 1, the attachment element comprising a mirror cover. |
| Claim K. | The protection device of claim 1, wherein the cover is made of PVC |
| Claim L. | The protection device of claim 1, the attachment element comprising an elastic closed loop. |
| Claim M. | The protection device of claim D, the lock strap comprising a flexible cut-resistant wire. |
| Claim N. | The protection device of claim C, wherein the attachment elements comprise Velcro™ |

Based on your analysis from question 1 and 2, review the list of dependent claims provided and rank the top 4 dependent claims in order of importance and value to the client. Provide a brief explanation for your ranking.

Question 4 [20 marks in total]

Craft the Detailed Description section of the patent specification to describe the invention claimed in questions 1, 2, and 3, including its embodiments and alternatives. The description should reflect the first independent claim (to an article of manufacture), the proposed second independent claim, and the dependent claims selected in question 3. (Note: This is the detailed description portion of the specification only. Do not provide a title, field of invention, summary of the invention, or description of the drawings.)

You are not expected to devise and describe embodiments or variants that are not explicitly described in the narrative, since you have no opportunity to question the inventor. However, you are required to provide a suitable description that uses formal language, reference numerals and that follows a logical order. The relevant features should be identified correctly

by using both broad and narrow language. This question focuses on the skill of describing the invention, not on the approach taken (ie on the scope of claim 1). **[20 marks]**

Question 5 [6 marks in total]

- (a) Identify two (2) available types of intellectual property protection other than patents based on the background provided (only the first two types provided will be marked) **[2 marks]**; and
- (b) Briefly outline practical and strategic timelines for securing patent protection for the invention claimed in question 2. **[4 marks]**.

Question 6 [3 marks in total]

Given the inventor's stated goals and the disclosures that have occurred, advise the inventor on the steps and timing for seeking patent protection in foreign countries that (a) have a 12-month grace period for filing and (b) require absolute novelty. **[3 marks]**