

College of Patent Agents & Trademark Agents

*Patent Agent Skills Examination
Part 2 Component B Sample Exam*

Purpose statement: The sample exam and sample answers are for informational and preparatory purposes only. They are intended to offer prospective test-takers a general understanding of the type and format of questions that may appear on the skills examination, as well as to demonstrate the level of detail expected in responses. For more information, refer to: <https://cpata-cabamc.ca/en/become-an-agent/information-patent-agent-qualifying-examinations/>

Representation: The sample exam does not represent the full range of topics, difficulty levels, or types of questions that may be encountered on the actual exam. The actual exam may contain questions that differ significantly in form and content.

Predictive value: Performance on this sample exam should not be taken as an indicator of future performance on the corresponding skills examination. This sample is not intended to predict exam outcomes and should not be used as a test-taker's sole preparation material.

Answer key: The sample answers provided are for illustrative purposes only. They represent one of several possible approaches to answering these sample questions. Actual exam responses may vary, and there may be multiple valid ways to address a question.

Updates and changes: Exam content and policies are subject to change. While we aim to keep our preparation materials up-to-date, the sample exam and answers may not reflect the most current version of the actual examination.

No guarantee: Using these sample materials does not guarantee success in the actual skills examination. Examinees are encouraged to engage in comprehensive study and preparation to enhance their understanding of the subject matter.

Confidentiality: The actual examination content is confidential.

Feedback: Feedback on these sample materials is welcome. However, please be aware that individual responses or specific guidance on exam preparation cannot be provided.

Examination information

The *Patent Agent Skills Examination Part 2* takes place over two (2) days. Test-takers have three (3) hours on one day to complete Component A, which focuses on prosecution as well as some aspects of validity and infringement. Test-takers have three (3) hours on a subsequent day to complete Component B, which focuses on validity and infringement. Each component is worth 75 marks; the two (2) components are scored together as a single examination worth 150 marks.

This is Component B. It consists of 8 questions worth a total of 75 marks.

Component B will be scored together with Component A.

During the examination, test-takers have electronic access to the *Patent Act*, RSC 1985, c P-4 (“Patent Act”) and *Patent Rules*, SOR/2019-251 (“Patent Rules”), in addition to other background information or resources necessary to respond to the examination questions.

Instructions for test-takers

Review any background information provided. Answer the questions.

Avoid extraneous commentary not directly relevant to the question (e.g., if a question requires an assessment as to novelty, do not comment on other criteria such as utility, obviousness, etc.) Do not assume facts that are not provided.

When asked to support an answer, include relevant discussion or reasoning. While relevant source references (e.g., to case law, statutory provisions, or regulatory provisions) may be helpful to include, separate marks are not provided for such references.

Point-form answers are acceptable.

Component B (3 hours, 75 marks)

Background

The following four documents are provided:

- **Subject Patent:** Canadian Patent No. 2,XXX,825 Pet Protective Cone Collar
- **D1 – Prior Art:** United States Patent No. 8,xxx,435 Veterinary Restraint Collar
- **D2 – Prior Art:** Canadian Patent No. 2,xxx,631 Pet Anti-Lick Collar
- **I1 – Infringing Device:** The Super Soft Pet Cone

The subject matter of this examination is pet cone collars, as may be used to prevent animals from scratching their facial regions or licking portions of their body. For those unfamiliar with pet cone collars, as shown in the prior art drawing below, the cone collar is formed from a sheet of material having an inner semi-circular arcuate edge with a smaller radius than an outer semi-circular arcuate edge of the sheet. The sheet of material is formed into a generally frustoconical shape in use and secured

about the animal's head. For example, this can prevent the animal from using its hind legs to scratch its eyes or ears.

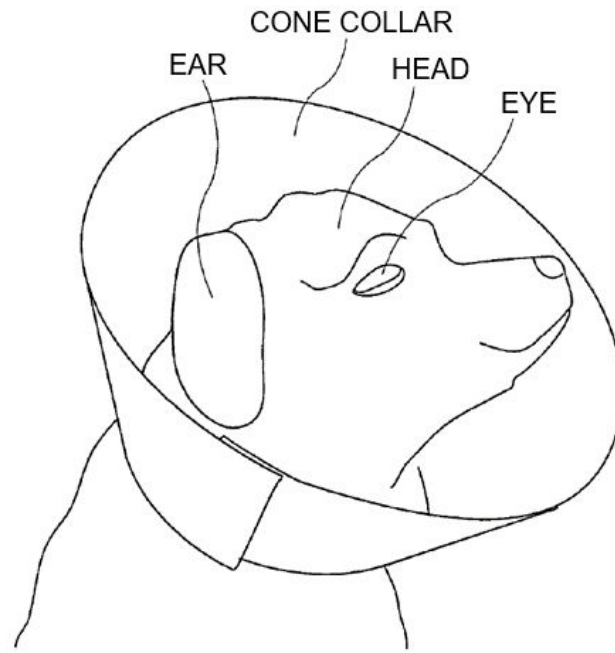

PRIOR ART

Fact Pattern

You have been retained by Pet Protectors Inc. to advise it on what action to take in response to infringement of the '825 PATENT by Soft Pets Ltd. Pet Protectors Inc. sells its protective pet collars in Canada through a non-exclusive licensee, Pet Mart Canada Inc., and Pet Mart Canada Inc. is threatening to terminate its partnership with Pet Protectors Inc. if the infringing conduct is not stopped.

Pet Protectors has retained a private investigator and determined how Soft Pets Ltd. is selling the Super Soft Pet Cone in Canada. The products are manufactured in China by SP Mfg. Co. to Soft Pets' specifications. Soft Pets takes delivery of the Super Soft Pet Cone in Guangdong, China, and ships the product from there to Toronto. Soft Pets sells the product in Canada directly to veterinarians, who use the Super Soft Pet

Cone to provide enhanced animal care in their clinics and who also sell the Super Soft Pet Cone to their consumers, and also through its licensee SP Distributing Inc.

As a cost-saving measure, Soft Pets also sells directly to consumers a low-cost model incorporating all of the components of the protective pet collar except for a mechanism for fastening the collar into its three-dimensional configuration. The low-cost model is accompanied by an illustrated instruction sheet directing consumers how to use separately purchased hook and loop fasteners backed with adhesive tape to size the collar to fit their specific animal by attaching the hook and loop fasteners onto the collar themselves.

The private investigator was also able to obtain the following information as to the sales of the fully assembled Super Soft Pet Cone in Canada to Soft Pet's licensee SP Distributing Inc. as follows:

- July 15, 2014, 1,200 Units
- December 15, 2014, 700 Units
- January 1, 2018, 1,500 Units

The private investigator also located a leaked internal memorandum from Soft Pets outlining Soft Pets' plans to start up a Soft Pets Research and Repair Centre. The Soft Pets Research and Repair Centre would conduct research using the Super Soft Pet Cone to better understand how the Super Soft Pet Cone could be manufactured to make it more effective. The Centre would also replace hook and loop fasteners on Super Soft Pet Cones returned by customers, as this component is known to wear quickly and detach from the main body of the pet cone.

The private investigator also determined that the person behind Soft Pets Ltd. is Karen Smith, one of the named inventors on the '825 PATENT. Your client advises that Karen used to be employed by Pet Protectors Inc. as its janitor. Karen did not have any written employment agreement with Pet Protectors Inc. and never signed any documents relating to the invention. She and Pet Protectors' product designer Joe Barnes came up with the idea for the invention claimed in the '825 PATENT over coffee one day at Pet Protectors' head office in Ottawa, sketching out drawings on

napkins at the coffee station that are substantially similar to what is reflected in the formal drawings of the '825 PATENT.

Question 1 [4 marks in total]

Assess the citability of D1 and D2 for anticipation and obviousness. Provide a brief explanation of why each document is citable or not. **[4 marks]**

Question 2 [16 marks in total]

Provide a construction of each of the following terms that you would present if representing the indicated party in an infringement action, and after providing such construction, explain how your construction supports a finding that the construed term is present in the Super Soft Pet Cone (II) (if representing the patentee) or is not present in the Super Soft Pet Cone (II) (if representing the alleged infringer).

Support your construction with appropriate explanation, having regard to the essential elements of each claim term as construed, explaining why an element is considered to be essential or non-essential. If you rely on a citation to a specific portion of the '825 PATENT to support your construction, you must specifically cite the relevant portion and explain how that citation supports your construction with reference to either the inventor's intent or material effect branch of the essentiality analysis. No marks are awarded for merely citing portions of or repeating passages of the '825 PATENT without explaining in your own words how and why they support your answer.

Scoring of each answer will be based on the organization and clarity of claim construction analysis in each component of this sub-question, including (a) specific identification of metes and bounds of the construed essential element, (b) supporting explanation of how claim construction is arrived at with explicit reference to both inventor's intent and material effect branches of essentiality analysis and (c) application of this claim construction to the facts of the problem.

(a) Representing the patentee, "a substantially flexible and resilient three-layer sheet " **[8 marks]**

(b) Representing the infringer, "a middle layer [of the three-layer sheet] provides the flexible and resilient properties [of the three-layer sheet]" **[8 marks]**

Question 3 [20 marks in total]

Complete the claim chart below and:

- (a) Assess whether claim 1 is anticipated by either one of D1 and D2; **[6 marks]**
and
- (b) Assesses whether claim 1 is obvious in view of the combination of D1, D2, and the common general knowledge. **[14 marks]**

Support your answer, with reference to relevant document sections and figures. For easy editing, select the chart/text you want to amend, and drag and drop it into the top left corner of the response box.

To facilitate providing your answer, a partially completed claim chart is supplied below. For part (a), 0.5 marks per blank space are awarded for completing the claim chart for each of D1 and D2 for a total of 5 marks, and 0.5 marks are awarded for each conclusion that D1 or D2 do or do not anticipate claim 1.

For part (b), 0.5 marks each to a total of 2 marks are awarded for completing the portions of the claim chart identifying any features taught by the common general knowledge, and 1 mark each to a total of 3 marks are awarded for explaining how certain features represent differences of the claimed invention relative to each of D1 and D2. The remaining 9 marks are awarded for applying the test for obviousness to the facts of the problem and the accompanying analytical reasoning.

No marks are awarded for inserting any reasoning or answer in shaded portions of the claim chart.

Claim 1	D1	D2	CGK (0.5 marks each for a total of 2 marks)	Differences from D1 and D2 (1 mark each for a total of 3 marks)
A protective pet cone collar comprising:	Yes, collar 10	Yes, collar 2		
a substantially flexible and resilient three-layer sheet				

Claim 1	D1	D2	CGK (0.5 marks each for a total of 2 marks)	Differences from D1 and D2 (1 mark each for a total of 3 marks)
having inner and outer arcuate edges extending between a first end and a second end of the sheet				
the inner and outer arcuate edges comprising single circular arcs,				
the outer arcuate edge having a radius that is greater than a radius of the inner arcuate edge; and				
at least one fastener	Yes, drawstring 19	Yes – adhesive buckle 5		
for securing the pet cone collar in a generally frustoconical three-dimensional configuration.				
Conclusion	(0.5 marks)	(0.5 marks)		

Question 4 [2 marks in total]

Identify and briefly explain one other potential issue, other than claim validity issues, that may affect the validity of the '825 PATENT. [2 marks]

Question 5 [8 marks in total]

Briefly explain whether the Super Soft Pet Cone infringes claims 1 (4 marks), 2 (1.5 marks) or 10 (2.5 marks) of the '825 PATENT. Support your answer with appropriate



citations to the relevant components of the Super Soft Pet Cone. It is recommended to use the claim chart below to provide your answer. For easy editing, select the chart/text you want to amend, and drag and drop it into the top left corner of the response box. **[8 marks]**

Claim 1	Mark Allocations
A protective pet cone collar comprising:	(0.5 marks)
a substantially flexible and resilient three-layer sheet	(0.5 marks)
having inner and outer arcuate edges extending between a first end and a second end of the sheet	(0.5 marks)
the inner and outer arcuate edges comprising single circular arcs,	(0.5 marks)
the outer arcuate edge having a radius that is greater than a radius of the inner arcuate edge; and	(0.5 marks)
at least one fastener	(0.5 marks)
for securing the pet cone collar in a generally frustoconical three-dimensional configuration.	(0.5 marks)
Conclusion	(0.5 marks)

Claim 2	Mark Allocations
A protective pet cone collar as defined in claim 1,	
wherein the three-layer sheet comprises an inner layer, a middle layer, and an outer layer,	(0.5 marks)
wherein the inner layer and the outer layer comprise a soft protective fabric.	(0.5 marks)
Conclusion	(0.5 marks)

Claim 10	Mark Allocations
A protective pet cone collar as defined in either one of claims 1	(0.5 marks)
or 2,	(0.5 marks)
wherein the fastener comprises a hook and loop fastener.	(0.5 marks)
Conclusion	(1.0 marks)

Question 6 [17 marks in total]

Based on the fact pattern provided and assuming that the Super Soft Pet Cone infringes claim 1 of the '825 PATENT, identify:

- (a) potential acts of infringement; **[8 marks]**
- (b) whether each party in the fact pattern is or is not liable for an act of direct infringement; **[5 marks]** and
- (c) whether any party is liable for inducing infringement. **[4 marks]**

Question 7 [4 marks in total]

List two defences potentially available to Soft Pets, and briefly state why each defence is potentially available. **[4 marks]**

Question 8 [4 marks in total]

Briefly state the remedy for patent infringement that is potentially available in respect of each of the sales made on July 15, 2014; December 15, 2014; and January 1, 2018. Do not consider the availability of equitable relief or costs. **[4 marks]**

DOCUMENTS

CA 2XXX825 C 2017/06/15

(11)(21) **2 XXX 825**(12) **BREVET CANADIEN**
CANADIAN PATENT
(13) C

(22) Date de dépôt/Filing Date: 2014/02/20	(72) Inventeurs/Inventors: SMITH, KAREN, CA BARNES, JOE, CA
(41) Mise à la disp. pub./Open to Public Insp.: 2014/08/21	(73) Propriétaires/Owners: PET PROTECTORS INC., CA
(45) Date de délivrance/Issue Date: 2017/06/15	
(30) Priorité/Priority: 2013/02/21	

[REMAINDER OF COVER PAGE AND ABSTRACT, AND SUMMARY OMITTED]**PET PROTECTIVE CONE COLLAR**Field of the Invention

[0001] The present invention, in some embodiments, relates to a pet protective cone collar. Some embodiments relate to a flexible pet protective cone collar that minimizes injury and discomfort to animals wearing the cone collar.

Background

[0002] Protective animal collars, commonly referred to as Elizabethan collars or cone collars, are roughly frustoconical in shape and designed to be worn around an animal's neck with the collar extending upward and outward around the animal's head. The collars are generally used to prevent an animal from licking or biting a wounded or diseased area on the animal's body. They can also be used to protect an animal's head or neck from scratching or rubbing with its paws.

[0003] Protective animal collars are commonly used after an animal has undergone a surgical procedure to prevent the animal from further aggravating the surgical site or disrupting the sutures and to decrease the risk of infection due to continued irritation of the site. However, they can also be used to prevent an animal from licking topically applied products such as medication or to prevent an animal from over-grooming.

[0004] Typically protective animal collars are made from flexible but fairly rigid material such as plastic or cardboard. The rigidity of the material prevents the animal from accessing the wounded or diseased area on its body with the more rigid materials doing a better job of keeping the head isolated. However, the rigidity of the material tends to negatively correlate with the animal's comfort in wearing the collar. Increasing rigidity also tends to increase the weight of the collar, which in turn increases the chaffing on the wearer.

[0005] Also, the more rigid the material, the more difficulty the animal has moving around and the more jarring for the animal if it runs into an object with the collar. Accordingly, there is a need for a protective animal collar that is functional and comfortable for the wearer, while still being able to retain a generally frustoconical shape to ensure the animal cannot access any wounded area on its body and/or to isolate the animal's head e.g. against scratching.

Description of the Drawings

[0006] FIG. 1 is a top view of an embodiment of the protective collar in the unfolded configuration.

[0007] FIG. 2 is a section view of the protective collar of FIG. 1 through line 2-2 of FIG. 1, depicting the arrangement of first and second exterior sheets and a padding layer and the stitching along each of the arcuate edges.

[0008] FIG. 3 is a perspective view of the protective collar of FIG. 1, as it would appear when fitted on an animal.

Detailed Description of the Invention

[0009] Referring to FIGS. 1, 2 and 3, the present invention provides a protective cone collar **1** effective as a veterinary restraint when fitted on an animal. In this embodiment of the invention the protective collar **1** comprises a first exterior sheet **10** comprising a soft and flexible material having inner and outer arcuate edges **12** and **14** respectively, the edges being generally concentric around a common centre and extending between a first end **16** and a second end **18**. A second exterior sheet **20** (underneath sheet **10** in FIG. 1 but visible in FIGs. 2 and 3) also comprises a soft and flexible material. The second exterior sheet **20** is substantially the same size and shape to enable creating the two sides of the collar with a space for a resilient support layer **22** to interpose the first and second exterior sheets **10**, **20**, as shown in FIG. 2.

[0010] The resilient support layer **22** is also of a generally similar shape to the first and second exterior sheets **10** and **20**, and is sized to be located between the first and second exterior sheets **10** and **20** as shown in FIG. 2. When assembled, the first and second exterior sheets **10** and **20** and the resilient support layer **22** form a substantially at least semi-circular shape, as has been shown in FIG. 1.

[0011] The materials selected for first and second exterior sheets **10**, **20** and resilient support layer **22** are selected to provide a three-layer construction that is flexible and resilient, without being rigid. The aforementioned design overcomes the disadvantages of substantially rigid prior art cone collars by providing greater comfort for the animal wearing the collar, as well as reducing harm to the animal and damage to property in the event the animal collides with objects such as people or furniture. In the event of such a collision, protective collar **1** will flex and yield, rather than transmitting the full force of the impact to the animal and the struck object, as is the case with more rigid prior art cone collars. Thus, a smaller proportion of the force of the impact will be transmitted to both the animal and the struck object by protective collar **1** than by other more rigid prior art cone collars.

[0012] However, the materials used in the three-layer construction, and in particular the material of resilient support layer **22**, are selected to be sufficiently resilient so that protective collar **1** will hold and return to its frustoconical shape after normal deformation, i.e. so that protective collar **1** will not buckle or fold during normal usage. Buckling or folding means that the generally frustoconical shape of protective collar **1** would be disrupted for a period of time (e.g. until a

user physically intervenes to restore the collar to its generally frustoconical shape), which might allow an animal to access an area intended to be protected by the protective collar **1**.

[0013] The desired level of flexibility and resiliency is generally provided by the material properties of the resilient support layer **22**, while first and second exterior sheets **10** and **20** act generally as protective covering layers, preventing physical damage to resilient support layer **22**. The first and second exterior sheets **10** and **20** can be fashioned from a variety of materials including cloth such as nylon, rubberized cloth, soft plastic and the like.

[0014] The resilient support layer **22** may also be fashioned from a variety of materials. The material used in the resilient support layer **22** should be flexible enough to provide a collar that is softer and therefore more comfortable than a traditional cone collar, yet is rigid enough to maintain the desired cone-like shape of the collar when worn by an animal and sufficiently resilient to return to its cone shape when bent, to avoid buckling of the collar during normal use. It is preferred that the first and second exterior sheets **10** and **20** be quite flexible with little resiliency and resistance to bending, while the resilient support layer **22** be more resilient such that when the three layers are formed into a unit and applied to an animal in a frustoconical cone shape, the collar will be sufficiently rigid to maintain its cone configuration yet will easily give when hit or pushed or bent, and will also be and resilient enough to thereafter recover its cone shape, avoiding buckling of the collar in normal use. Foam plastic is a good material for use as the resilient support layer, and a wide range of resiliency and thickness is available.

[0015] In the embodiment of FIGS. 1, 2 and 3 the resilient support layer **22** comprises a layer of resilient foam sandwiched between the first and second exterior sheets **10** and **20**, as shown in FIG. 2. Other materials such as soft rubber or like materials may be used to provide a sufficiently resilient and flexible support layer. The first exterior sheet **10** and the second exterior sheet **20** are joined along their peripheries **12** and **14** by sewing.

[0016] In the embodiment shown in FIGS. 1, 2 and 3, separate exterior sheets **10** and **20** are sewn together along the inner arcuate edge **12** and the outer arcuate edge **14** using conventional hem sewing techniques. While there are many different types of specialized hem stitches that are known and which can result in different stiffness properties of the edge of the material provided by the hem, all such edges being more rigid than an unhemmed edge, but some such edges being

more rigid than a conventional hem sewing technique and some being less rigid than a conventional hem sewing technique. Conventional hem sewing techniques or another technique that produces a similarly rigid edge are preferred to reinforce the strength of the materials being joined together, and allow the formation of a strong and sufficiently rigid edge at the junction of the two exterior sheets **10** and **20** to minimize buckling. Formation of such a reinforced edge using conventional hem sewing techniques as aforesaid can help to strengthen protective collar **1**, and can help to avoid damage or the buckling of protective collar **1** if outer arcuate edge **14** collides with objects while protective collar **1** is worn by an animal.

[0017] In some embodiments, inner arcuate edge **12** and outer arcuate edge **14** are further reinforced beyond the reinforcement provided by the conventional hem sewing technique by using inner and outer hem strips **26** and **24** to join exterior sheets **10** and **20**, as shown in FIG. 2, with the resilient support layer **22** inside. This further helps to avoid damage and prevents the protective cone collar **1** from buckling if outer arcuate edge **14** is strongly impacted against objects by the animal wearing protective collar **1**.

[0018] Stitching can also be used to further strengthen the collar. Radially extending stitching **28a**, **28b** and **28c** (FIG. 1), each comprising two parallel rows of stitching in the illustrated embodiment, provides some additional rigidity radially, and further strengthens the integrity of the collar against buckling when in use. The preferred stitching is zigzag type or parallel rows of straight stitching that is of a selected width dimension such as about $\frac{1}{8}$ inch to about $\frac{1}{4}$ inch and the stitching extends fully and continuously across the material of the collar from the arcuate edge **14** to the arcuate edge **12** so that the protective collar **1** benefits from enhanced support and rigidity along its entire length. If stitching **28a**, **28b** and **28c** did not extend fully in a continuous line from arcuate edge **14** to arcuate edge **12**, then weak points could be created along the length of protective collar **1** that might allow the collar to buckle and fold, thereby failing to return to its frustoconical shape after deformation by an impact.

[0019] The invention further comprises a means of closure, effective to secure the ends of the protective collar, such that when the ends of the protective collar are secured, the collar forms a truncated cone with an inner opening **30** and an outer opening **32** as shown in FIG. 3. Various means of closure are suitable for use in the invention. In one embodiment hook and loop fastener

strips such as Velcro™ products conveniently secure the ends of the collar to form the desired cone shape as shown in FIG. 3. In the embodiment shown in FIGS. 1, 2 and 3, a plurality of first hook and loop strips **34** are on the exterior sheet **10** (facing up in FIG. 1), and are positioned and configured to be mated with at least one of a corresponding mating plurality of three second hook and loop strips **36** that are provided on the exterior sheet **20** (facing down in FIG. 1). One or more tabs **38** of Velcro™ can also be provided to serve a similar purpose.

[0020] Conveniently, a number of neck closure means may be provided in order to provide the ability to fashion a protective collar capable of fitting different size animals. As shown in FIGS. 1 and 3, a series of loops **54** are sewn into the inner hem. These can be made of elastic material so as to stretch to accept the pet's normal collar. Alternatively, as shown in FIG. 3, a drawstring or other fastening member **60** can be threaded through the loops **54** and used to secure protective cone collar **1** in place on an animal.

[0021] When placed on an animal, the inner opening **30** is adapted to fit securely around the neck of the animal, and the outer opening **32** is of sufficient size to prevent the animal fitted with the protective collar from contacting an area of the body to be protected.

[0022] The invention further provides a method of using a pet protective collar as described above as a veterinary restraint. The method comprises placing a collar such as that described herein around the neck of an animal, and securing as described. Conveniently, the collar of the invention is suitable to protect an area from contact by the animal's mouth, and yet is comfortable enough to wear that the animal will tolerate the collar.

[0023] The collar is thus suitable for use in a method of protecting a wound from a surgical procedure, an injury that is non-surgical in nature, or to prevent mouth contact of an area to which a topical medicament has been applied.

[0024] While various embodiments of the present invention have been described above, it should be understood that they have been presented by way of example only, and not of limitation.

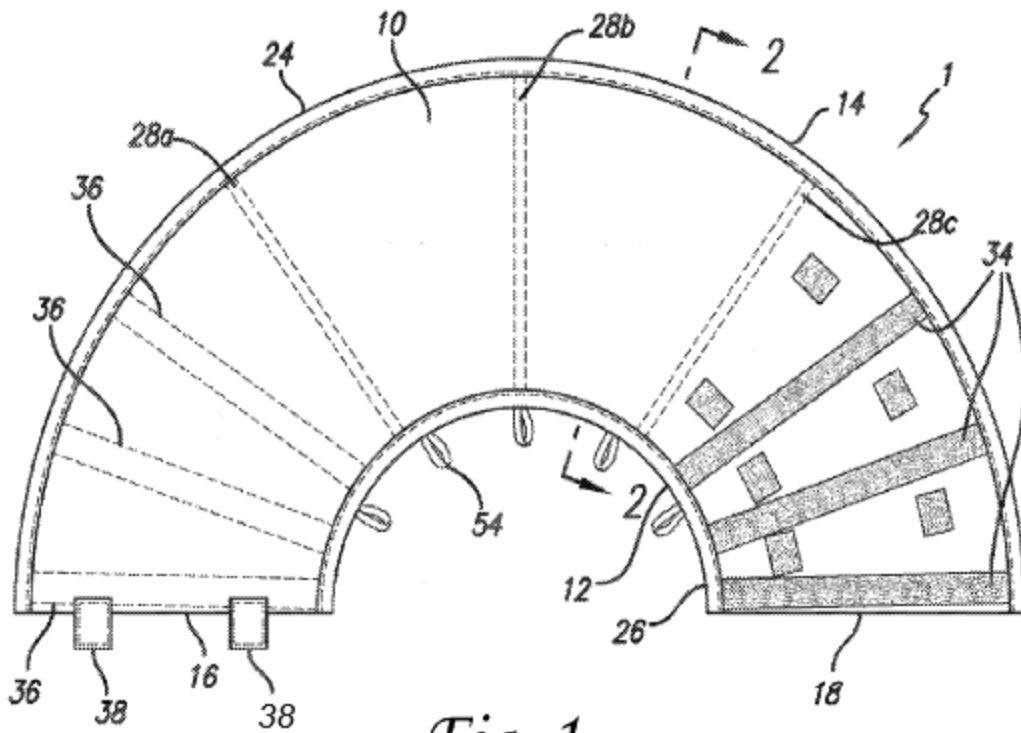

Fig. 1

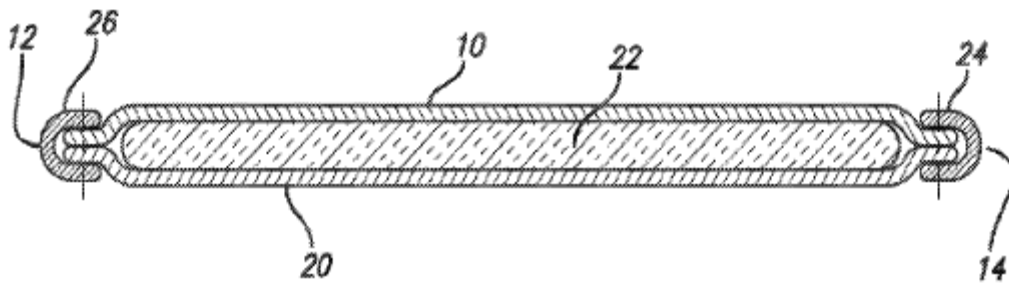

Fig. 2

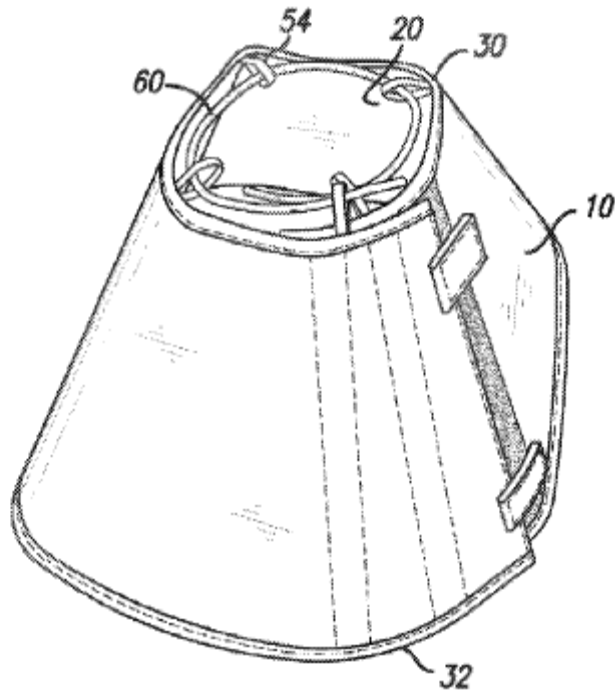

Fig. 3

Claims

1. A protective pet cone collar comprising:

a substantially flexible and resilient three-layer sheet having inner and outer arcuate edges extending between a first end and a second end of the sheet,

the inner and outer arcuate edges comprising single circular arcs,

the outer arcuate edge having a radius that is greater than a radius of the inner arcuate edge; and

at least one fastener for securing the pet cone collar in a generally frustoconical three-dimensional configuration.

2. A protective pet cone collar as defined in claim 1, wherein the three-layer sheet comprises an inner layer, a middle layer, and an outer layer, wherein the inner layer and the outer layer comprise a soft protective fabric.

3. A protective pet cone collar as defined in claim 1, wherein a middle layer of the three-layer sheet provides the flexible and resilient properties of the three-layer sheet.

4. A protective pet cone collar as defined in claim 2, wherein the middle layer comprises a resilient foam.

5. A protective pet cone collar as defined in claim 1, wherein the three-layer sheet

comprises a plurality of support elements extending between the inner and outer arcuate edges.

6. A protective pet cone collar as defined in claim 5, wherein the plurality of support elements comprise rows of stitching.

7. A protective pet cone collar as defined in claim 1, wherein the outer arcuate edge comprises a reinforced edge.

8. A protective pet cone collar as defined in claim 7, wherein the reinforced edge comprises a conventional hem stitch.

9. A protective pet cone collar as defined in claim 8, wherein the reinforced edge further comprises a hem strip.

10. A protective pet cone collar as defined in either one of claims 1 or 2, wherein the fastener comprises a hook and loop fastener.

DOCUMENT D1

United States Patent No. 8,xxx,435

Issue Date: June 14, 2011

VETERINARY RESTRAINT COLLAR

Filing Date: April 24, 2008

Publication Date: August 21, 2008

Priority Data: Continuation of application No. 10/xxx,281 filed on Nov. 13, 2004

1 A veterinary restraint collar for a cat, comprising two side-by-side rings of soft, flexible and non-
2 resilient medical padding material sewn together along their inner margins and having a
3 drawstring passage with a "stretch" gauze drawstring in the passage. The rings have adjacent
4 faces of thin plastic sheet material, and opposite faces of soft absorbent material, and are
5 gathered to form radial pleats. The rings stand out from the neck hole to form a flexible barrier
6 restricting the animal's ability to reach portions of its body with its mouth.

7 As shown in the drawings for purposes of illustration, the invention is embodied in a veterinary
8 restraint collar, indicated by the reference number **10**, for use on an animal **11**, herein a cat, to
9 restrict access of the animal's head **12** and mouth **13** to the remainder of the body **14**.

10 As can be seen, the illustrative collar **10** comprises two soft, floppy rings **15** and **17** that are of
11 approximately the same size and shape and are disposed in side-by-side relation. The rings are
12 joined together along their radially inner margins to form a generally circular neck hole for
13 receiving the neck of the cat. A drawstring **19** is provided around the neck hole for tightening of
14 the collar and releasably securing it in place.

15 The collar rings **15** and **17** of the collar **10** are composed of soft, flexible and non-resilient
16 material that has sufficient body to form a floppy collar that stands out to some extent from the
17 neck opening but insufficient rigidity to give the animal the feeling of having its head confined,
18 in a frustro-conical funnel, as in many of the prior art devices, or other wise. In this way, the
19 invention significantly reduces the discomfort of the animal, and produces a minimal

20 interference with its comfort and ability to move around. In effect, the invention provides a soft,
21 flexible barrier between the head and the rest of the body, rather than an annoying, frightening
22 rigid or semi-rigid “container” around the head as for traditional Elizabethan collars.

23 It will be noted that the rings **15** and **17** are gathered around the neck hole **18**, forming radiating
24 irregular folds or pleats in the rings as indicated at **27**, **28**, **29**, **30** and **31**. While these can be
25 eliminated by cutting the material in bands of uniform width, it is believed that the gathers
26 contribute desirable body to the body of the collar and its ability to stand out from the neck
27 holes, without materially increasing the discomfort of the animal.

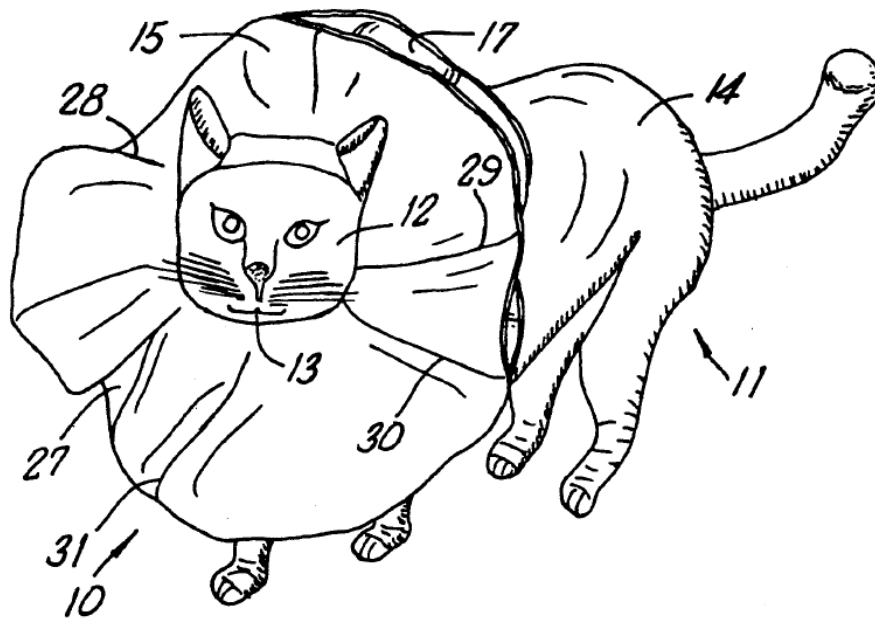

DOCUMENT D2

Canadian Patent No. 2,xxx,631

Issue Date: June 23, 2015

PET ANTI-LICK COLLAR

National Entry: January 25, 2013

PCT Filing Date: July 28, 2011

Publication Date: February 2, 2012

PCT: PCT/CN2011/xxx,710

Priority Data: CN 2010xx,xxx,xxx.3 filed on July 28, 2010

1 As shown, the present invention includes a ring-shaped collar **2** and a soft cloth protection ring **3**
2 sewn on the periphery of the collar **2**. The collar **2** and the protective ring **3** have openings **6**
3 respectively, and adhesive buckles **5** are respectively connected to the openings **6** on both sides
4 of the collar **2**. The collar **2** is made of a cloth outer layer wrapped with a sponge filler. The
5 protective ring **3** is made of two layers of polyester cloth that surround a sponge filler to give the
6 structure rigidity and resiliency. The protective ring **3** is formed from a plurality of segments
7 held together by stitching **4**, which is convenient for processing and which helps to prevent
8 collapse of the protective ring **3** (e.g. if the animal wearing collar **2** crashes into an object). The
9 device prevents pets from licking wounds or affected areas with their tongues

10 When in use, the adhesive buckle **5** is opened, the opening **6** is opened, and the collar **2** is put on
11 the pet's neck. By adjusting the opening size of the opening **6** and cooperating with the buckle **5**,
12 the collar **2** is put on the pet's neck, and then the adhesive buckle **5** is fastened.

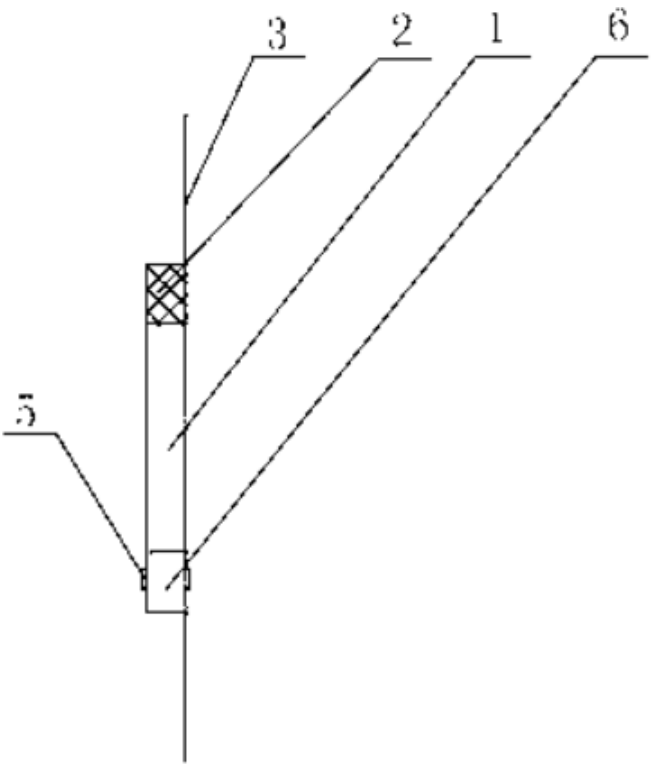
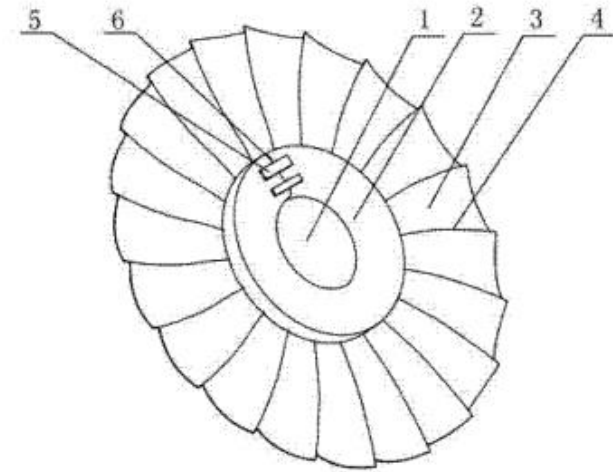

DOCUMENT 11: THE SUPER SOFT PET CONE

1 As can be seen in the top view of FIG. A and the cross-sectional view of FIG. B taken through
2 line B—B in FIG. A, the Super Soft Pet Cone is a cone collar **P** that has a first exterior sheet **C**
3 and a second exterior sheet **D**. First and second exterior sheets **C**, **D** are made from a generally
4 soft and flexible material such as nylon. Interposing first and second exterior sheets is a layer of
5 loose fill material **E**.

6 Fill material **E** is a generally soft and loose bulk material, such as down (duck feathers) or cotton
7 batting as might be used to provide insulation in a winter coat. During manufacture of cone
8 collar **P**, fill material **E** is very firmly packed in between first and second exterior sheets **C**, **D**, so
9 that although fill material **E** itself is soft and collapsible, the overall structure of exterior sheets
10 **C**, **D** and fill material **E** is quite resilient, so that cone collar **P** will return to its generally
11 frustoconical shape after being bent, for example by reason of a collision with an object.

12 As can be seen in FIG. B, first and second exterior sheets **C**, **D** are sewn together at the outer
13 arcuate edge **F** with a blind hem stitch while the inner arcuate edge **G** has a conventional hem
14 stitch with a hem strip **H**. A blind hem stitch is different from a conventional hem stitch in that it
15 provides a much narrower line of stitching from conventional hem stitching techniques, with the
16 stitching being hidden inside the hem. The result of this is that the blind hem stitch provides a
17 much softer and more flexible edge than does a conventional hem stitch, even though the edge is
18 slightly more stiff and rigid than an unhemmed edge would be.

19 This makes the outer arcuate edge **F** more flexible than inner arcuate edge **G**, which is reinforced
20 with hem strip **H** to help maintain the generally circular shape of the opening in cone collar **P**.

21 The construction of outer arcuate edge **F** using a very soft blind hem stitch can help to minimize
22 impacts to the animal and to objects struck by the collar in the event of collisions, because outer
23 arcuate edge **F** will yield significantly on any such impact. In some cases, this may result in the
24 generally frustoconical shape of cone collar **P** being disrupted during normal use, as the outer
25 arcuate edge **F** may buckle under the force of some impacts, thereby disrupting the generally
26 frustoconical shape of the collar and requiring an animal's caretaker to intervene to physically
27 unbend the collar at the point where it buckled, to restore the generally frustoconical shape.

28 While this may be inconvenient to pet guardians, allowing such buckling to occur in response to

29 harder impacts as may be experienced during normal use helps to keep cone collar **P** soft and is
30 important to avoiding injury, particularly to smaller animals such as puppies or cats.

31 The Super Soft Pet Cone is also provided with radial stitching **I** to further strengthen cone collar
32 **P** to help it maintain its frustoconical shape in a greater range of circumstances. Radial stitching
33 **I** does not extend to the outer arcuate edge **F** or to the inner arcuate edge **G** but rather stops short
34 of them leaving a space **J** adjacent the outer arcuate edge **F**. There is also a space **K** adjacent the
35 inner arcuate edge **G**. The spaces **J** and **K** allow for easy bending, thereby ensuring that the
36 collar is flexible and yields on impact with a struck object, again minimizing the risk of injury to
37 the animal or damage to property if the animal collides with objects while wearing the Super Soft
38 Pet Cone, although the cone collar **P** may thereby be more likely to buckle in certain
39 circumstances during normal use than if radial stitching **I** extended fully and continuously
40 between outer arcuate edge **F** and inner arcuate edge **G**.

41 Ends **L** and **M** have near them fasteners such as strips of mating Velcro™ **N** and **O**. Also a tab **Q**
42 can fasten either to one of the strips **O** or to a patch **R**. This allows the Super Soft Pet Cone **P** to
43 be assembled into a generally frustoconical shape encircling an animal's neck and secured in
44 place on the animal's collar using loops **S**.

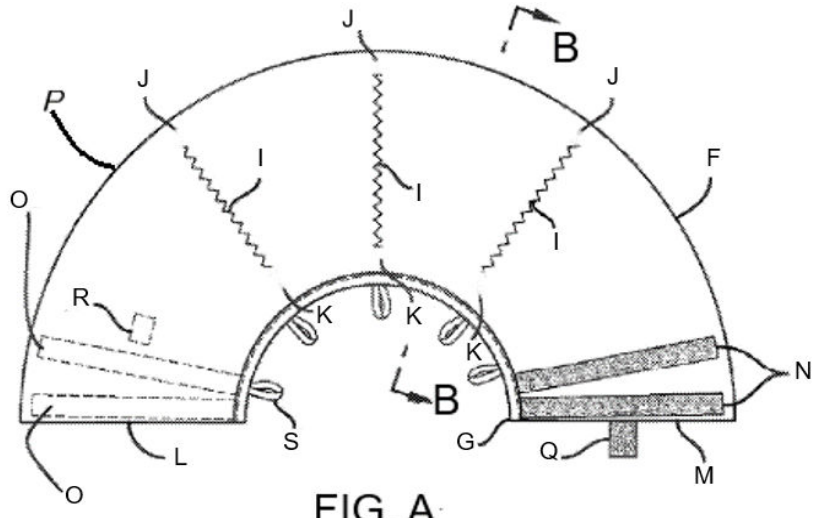

FIG. A

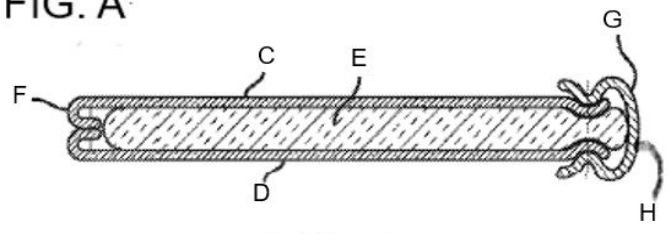

FIG. B